

When placing an order

The aspect that needs to be taken into consideration when ordering a product is that tension straps are measured differently for different countries and companies, both internally and externally. Before placing an order, please specify the measurement code (a or b) for your request

A code: internal measurement

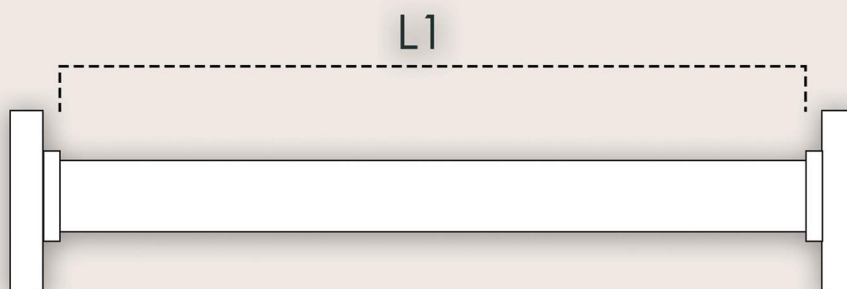

B code: external measurement

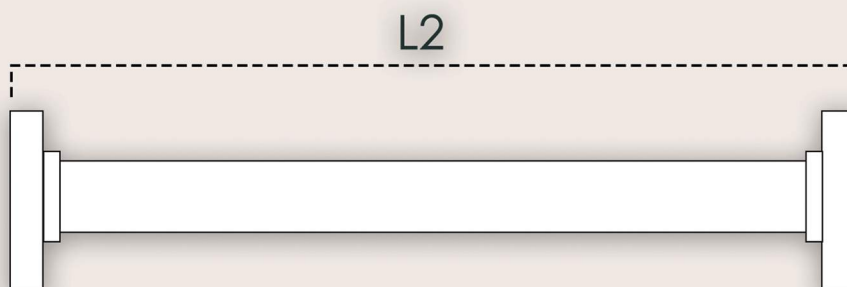

important note

SINGLE BUTTON MODEL

The single button model is especially designed for furniture manufacturers producing bergere. It is very easy to apply, saves time, and speeds up production. At the same time, it contributes to the longevity of the seat and increases comfort by ensuring the integrity of the fabric and filling material and preventing them from falling apart.

We manufacture the single button model in accordance with industry standards for strength.



20-90mm
160-150mm
170-175mm
180-185mm
190-195mm
200-205mm
210-220mm
225-230mm
235-240mm
245-250mm
255-260mm
265-270mm
275-280mm
285-290mm
290-300mm
305-400mm
405-500mm
505-600mm
605-700mm
700- ∞

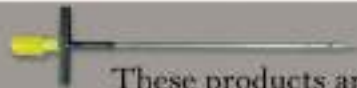

These products are applied with a T handle needle.

DOUBLE BUTTON MODEL

The double button model is preferred in buttoned seat models, as well as in bed bases and buttoned chair models. It provides a connection between the button and the frame, and also provides stretch that is not found in the studded button.

In studded button applications, the fabric, bottom filling materials (such as sponge, felt, fiber, etc.) form a very tight structure, which reduces stretching.

However, in our double button model, the weaving band between the materials allows for more stretching and increases the comfort of the end user.

The double button model is a preferred option for sofa, bed, and chair manufacturers who prioritize quality and comfort.

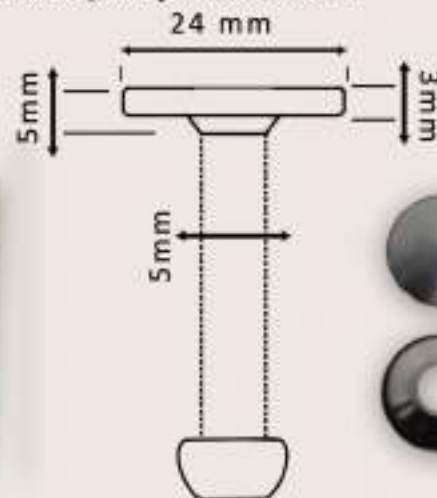

20-90mm
160-150mm
170-175mm
180-185mm
190-195mm
200-205mm
210-220mm
225-230mm
235-240mm
245-250mm
255-260mm
265-270mm
275-280mm
285-290mm
290-300mm
305-400mm
405-500mm
505-600mm
605-700mm
700- ∞

NEW DOUBLE BUTTON MODEL

Although the GR01 A has the same purpose and features, the new model with double buttons is preferred as a fastener in sofas. It allows for modular fixation of the filling material on the frame and can be disassembled and mounted when necessary.

We manufacture the new double button model to meet technical strength requirements.

20-90mm
160-150mm
170-175mm
180-185mm
190-195mm
200-205mm
210-220mm
225-230mm
235-240mm
245-250mm
255-260mm
265-270mm
275-280mm
285-290mm
290-300mm
305-400mm
405-500mm
505-600mm
605-700mm
700- ∞

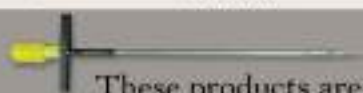
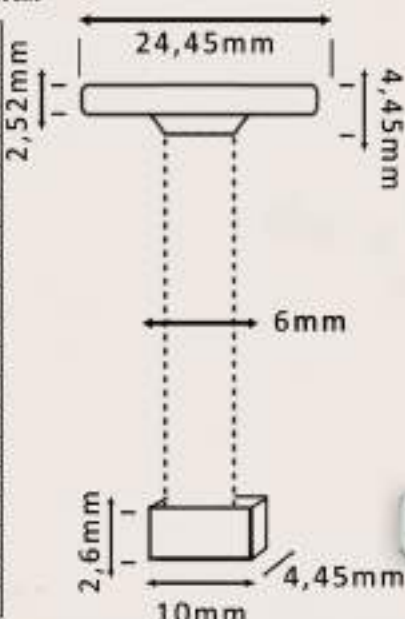

These products are applied with a T handle needle.

NEW DOUBLE MODEL

This product is generally used in sofas, but it can also be used in beds.

We manufacture the new double button model to meet technical strength requirements.

20-90mm
160-150mm
170-175mm
180-185mm
190-195mm
200-205mm
210-220mm
225-230mm
235-240mm
245-250mm
255-260mm
265-270mm
275-280mm
285-290mm
290-300mm
305-400mm
405-500mm
505-600mm
605-700mm
700- ∞

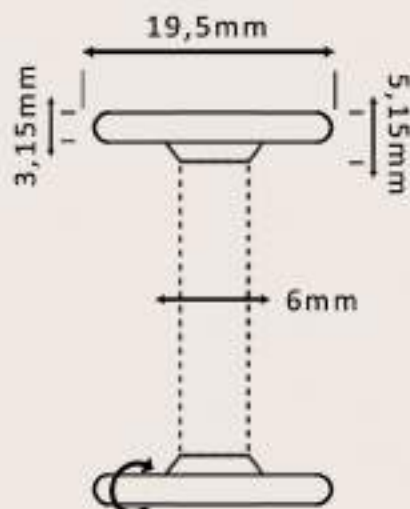

SHORT DOUBLE MODEL

The short double model provides great support for quilting in buttoned couch models, speeds up the process, and saves labor. It ensures a tighter grip of the fabric on the skeleton, reducing the load on the button. Even if the button is damaged when the end-user uses it, it prevents the fabric from coming outwards, extending the product life. Furniture manufacturers who care about quality also prefer the short double model along with our other models. The technical durability of the short double model is produced in accordance with standards, guaranteeing a high-quality product.

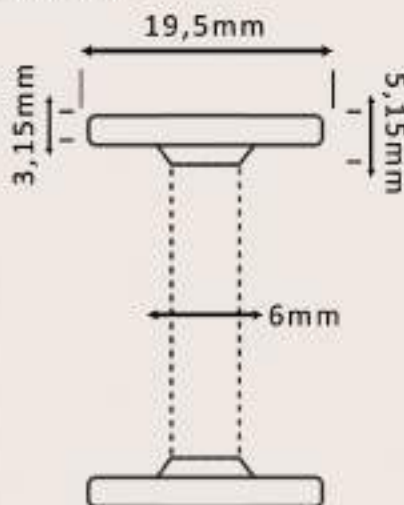

20-90mm
160-150mm
170-175mm
180-185mm
190-195mm
200-205mm
210-220mm
225-230mm
235-240mm
245-250mm
255-260mm
265-270mm
275-280mm
285-290mm
290-300mm
305-400mm
405-500mm
505-600mm
605-700mm
700- ∞



These products are applied with a T handle needle.

SINGLE TUFTING TAPE

Single tufting tape is mostly used in sofas. It is sewn to the sofa fabric to help it adhere to the frame and extend the product's life. This increases the product's durability and improves its quality, making it a preferred product among sofa manufacturers.

We produce the single tufting tape in accordance with industry standards for technical strength.

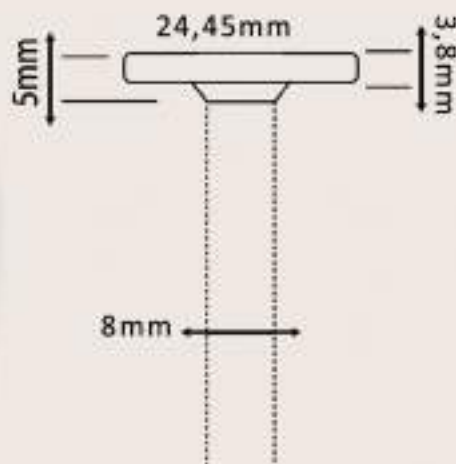

25-90mm
160-150mm
170-175mm
180-185mm
190-195mm
200-205mm
210-220mm
225-230mm
235-240mm
245-250mm
255-260mm
265-270mm
275-280mm
285-290mm
290-300mm
305-400mm
405-500mm
505-600mm
605-700mm
700- ∞

T HANDLE NEEDLE

The needle preferred by sofa manufacturers is easy to use. It is a price/performance product with its durability and performance. This needle is used in our models designed for armchairs. We produce the technical strength of the single tufting tape in accordance with the standards.

BUTTONS

The UFO button model is a fabric-covered button that can be used in our products GR01, GR01 A, and GR07.



DOUBLE TUFTING TAPE

The double tufting tape is used as a technical support material for products such as beds, armchairs, and sofas. It is combined with felt and pompom to avoid damaging the mattress fabric and to ensure the safety of the end user when applied to the mattress. It is preferred for increasing the durability of armchairs and sofas. We manufacture the double tufting tape to meet industry standards for technical strength.

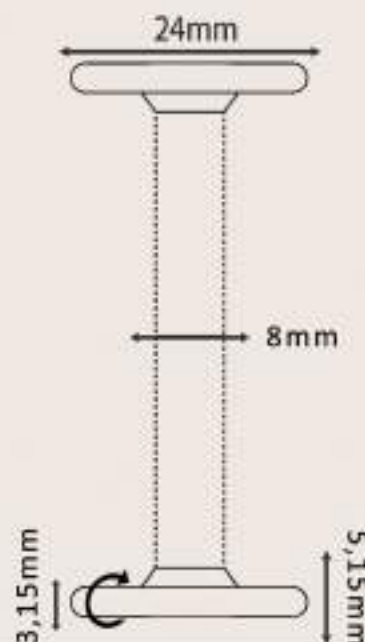

20-90mm
160-150mm
170-175mm
180-185mm
190-195mm
200-205mm
210-220mm
225-230mm
235-240mm
245-250mm
255-260mm
265-270mm
275-280mm
285-290mm
290-300mm
305-400mm
405-500mm
505-600mm
605-700mm
700- ∞



These products are applied with a semi-automatic needle with a wooden handle.

ING MODEL1 ING MODEL2

The ING Model tape is used as a technical support material for products such as beds, armchairs, and sofas. It is combined with felt and pompom to avoid damaging the mattress fabric and to ensure the safety of the end user when applied to the mattress. It is preferred for increasing the durability of armchairs and sofas.

We manufacture the ING Model tape to meet industry standards for technical strength.

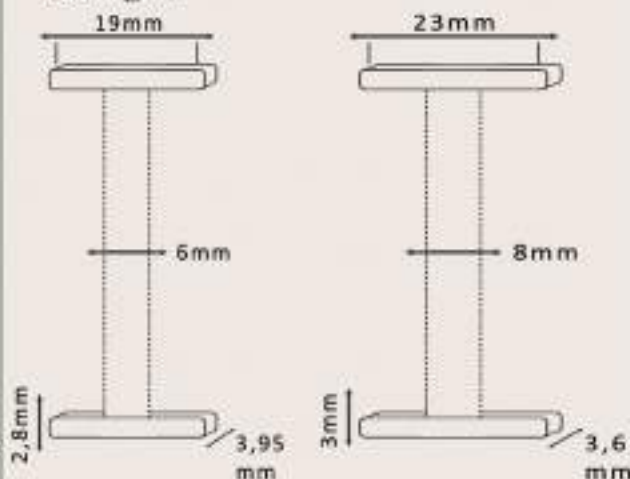

20-90mm
160-150mm
170-175mm
180-185mm
190-195mm
200-205mm
210-220mm
225-230mm
235-240mm
245-250mm
255-260mm
265-270mm
275-280mm
285-290mm
290-300mm
305-400mm
405-500mm
505-600mm
605-700mm
700- ∞

BUTTON THREAD WITH HOOK

This product, which is manufactured in accordance with the old production method, is used as a fastener. It is preferably used in delicate furniture fabrics. Despite its disadvantages, there are areas of use.

We produce hooked button rope in accordance with technical strength.

50-90mm
160-150mm
170-175mm
180-185mm
190-195mm
200-∞ mm



These products are applied with a semi-automatic needle with a wooden handle.

DOUBLE BUTTON PILLOW MODEL

The model, which is designed to have buttons on both ends, is preferably suitable for thick pillow fabrics. Increases quality and durability. It speeds up production. Eliminates the possibility of the button coming off. We produce the double button pillow model in accordance with technical strength.

20-90mm
160-150mm
170-175mm
180-185mm
190-195mm
200-205mm
210-220mm
225-230mm
235-240mm
245-250mm
255-260mm
265-270mm
275-280mm
285-290mm
290-300mm
305-400mm
405-500mm
505-600mm
605-700mm
700-∞

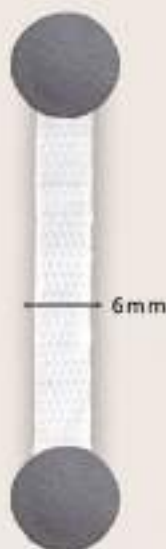

WOODEN HANDLE SEMI-AUTOMATIC NEEDLE

This needle is preferred by mattress manufacturers for double tufting tape applications as it speeds up work and is easy to apply. The triangular pointed tip is strong enough to pierce all types of filling materials. The spring system can be adjusted according to the bed thickness and can be adapted to the user's working style. We manufacture the semi-automatic needle with a wooden handle in accordance with industry standards for technical strength.



WOVEN STRIPES

In addition to standard stock production in sizes of 6 mm, 8 mm, and 9 mm, we also offer customized production of weaving strips in various sizes and colors. These woven strips are commonly used by sofa and mattress

manufacturers as tensioning or binding ropes and are made of high-quality polyester material.

At our company, we produce weaving strips in compliance with industry standards to ensure their strength and durability.



POMPOM

Pompom, which is produced from hand-knitting yarns consisting of a mixture of acrylic and wool, is a product mostly preferred by mattress manufacturers. It is used in tufting tape applications to prevent the tufting tape's plastic from harming the end-user. It is also used as an ornament in beds.

We manufacture the pompom in accordance with technical strength. There are different options of pompoms available, including wool, acrylic, fiber, and cotton. All products have color options available.

wool

acrylic

cotton

fiber



These products are applied with a semi-automatic needle with a wooden handle.

FELT

The felt, produced in two different sizes, has the appearance of a daisy. Manufacturers use it between the fabric and the tension band plastic in order to minimize damages that may occur in the fabric during double tufting tape applications. This product is made from felt material formed by pressing polyester fiber. Wool felts are also available. We produce the felt in accordance with technical strength standards.

